

1.0 Overall Concept

The basic concept of a digital organ is shown in figure 1. The organ keys are connected to a digital keyboard encoder which generates electrical signals that a computer can recognize. The computer generates proper sounds from the keys that are pressed. That sound signal is amplified for use with a loudspeaker.

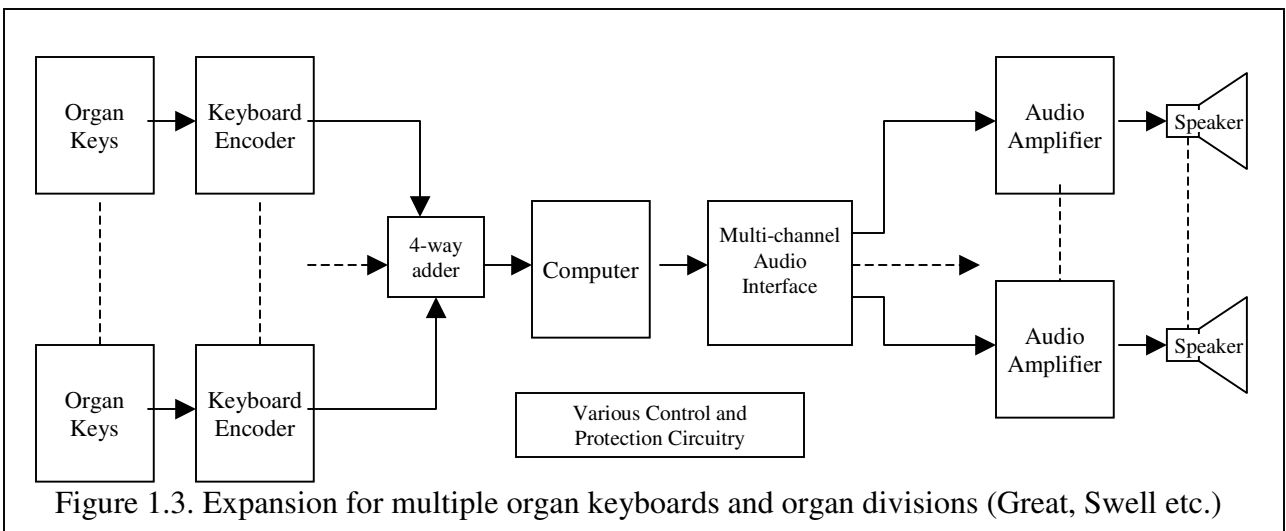

A complete block diagram of the digital installation at CUMC is shown in figure 1-4. This is an expansion of the basic concept from Figure 1-3 with various extensions that make the system practical when integrated with the existing Moller pipe organ. The function of the various assemblies need to be explained, as well as the locations and wiring points.

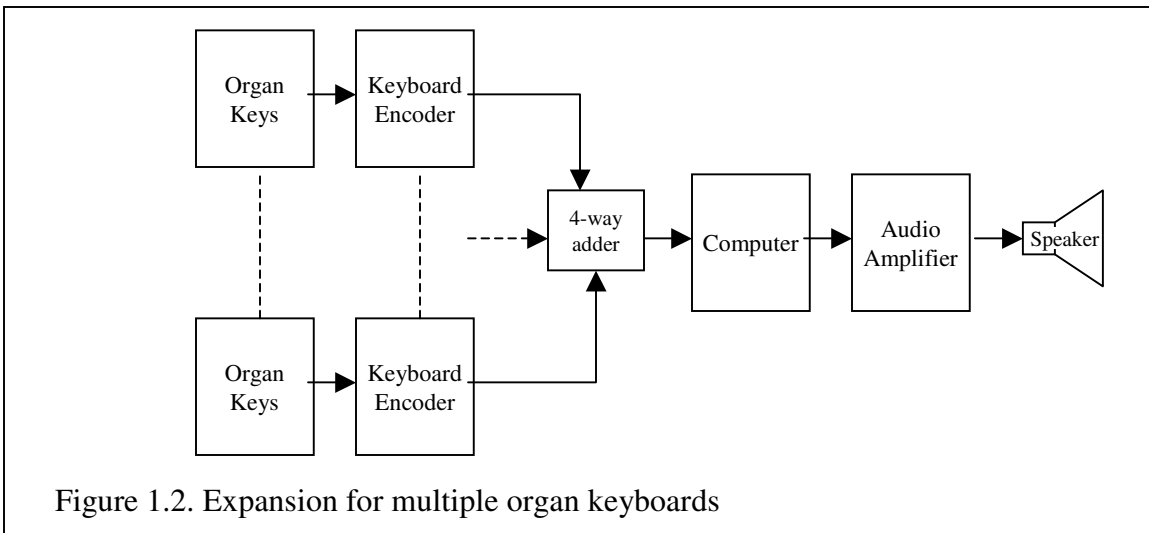
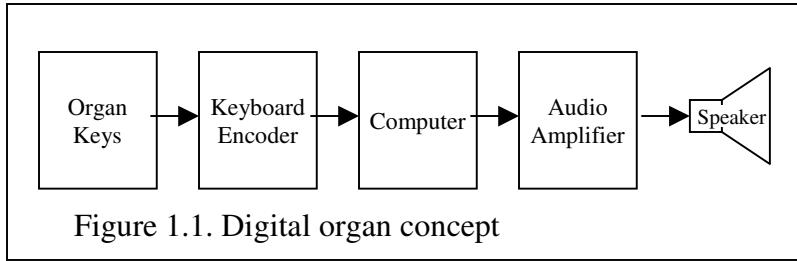
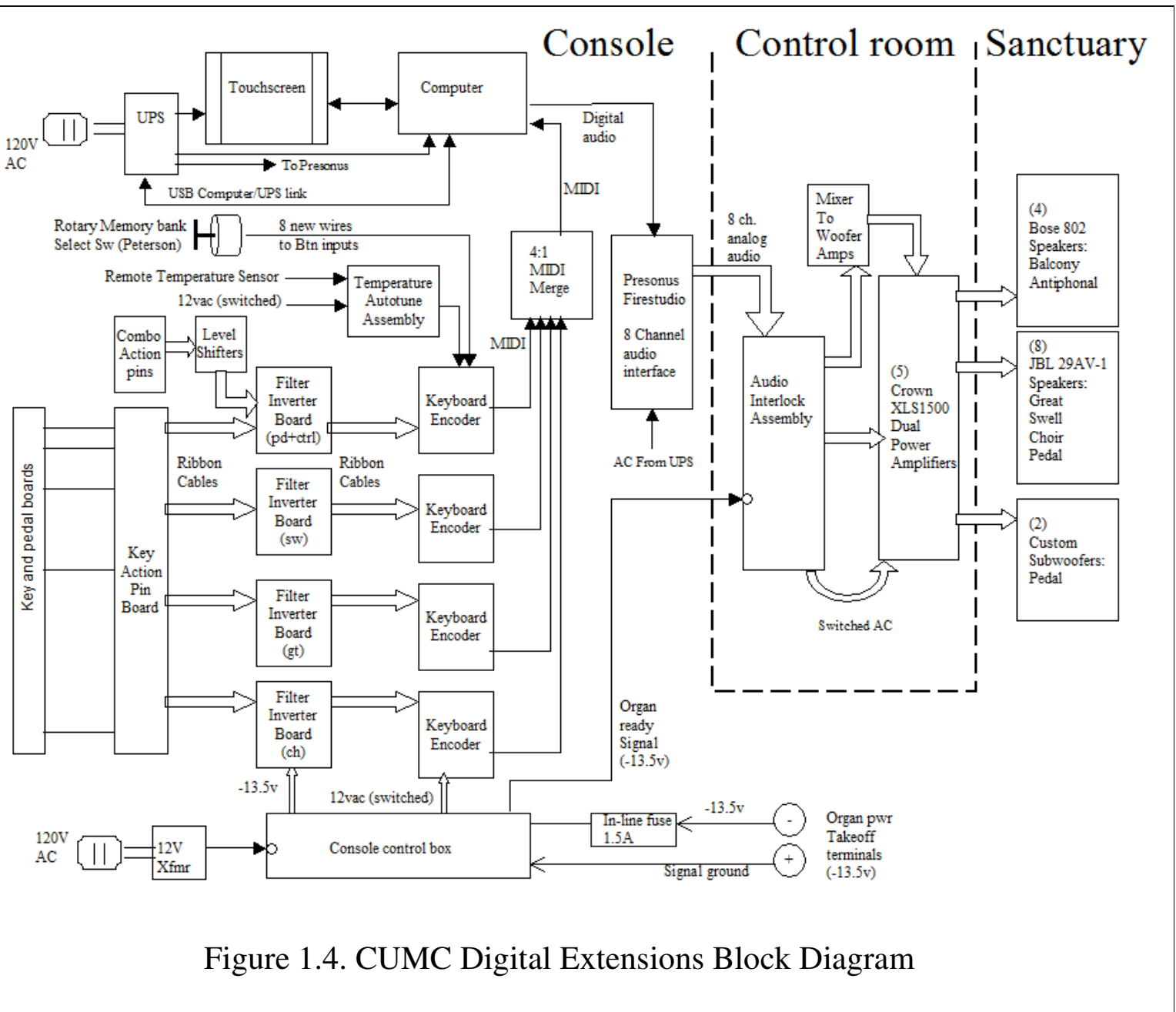

Figure 1.4. CUMC Digital Extensions Block Diagram

Component placement.

This is the organ console viewed from the rear with the back panel removed. The Filter-Inverter boards are located behind the keyboard encoders. This mounting board folds down for maintenance.

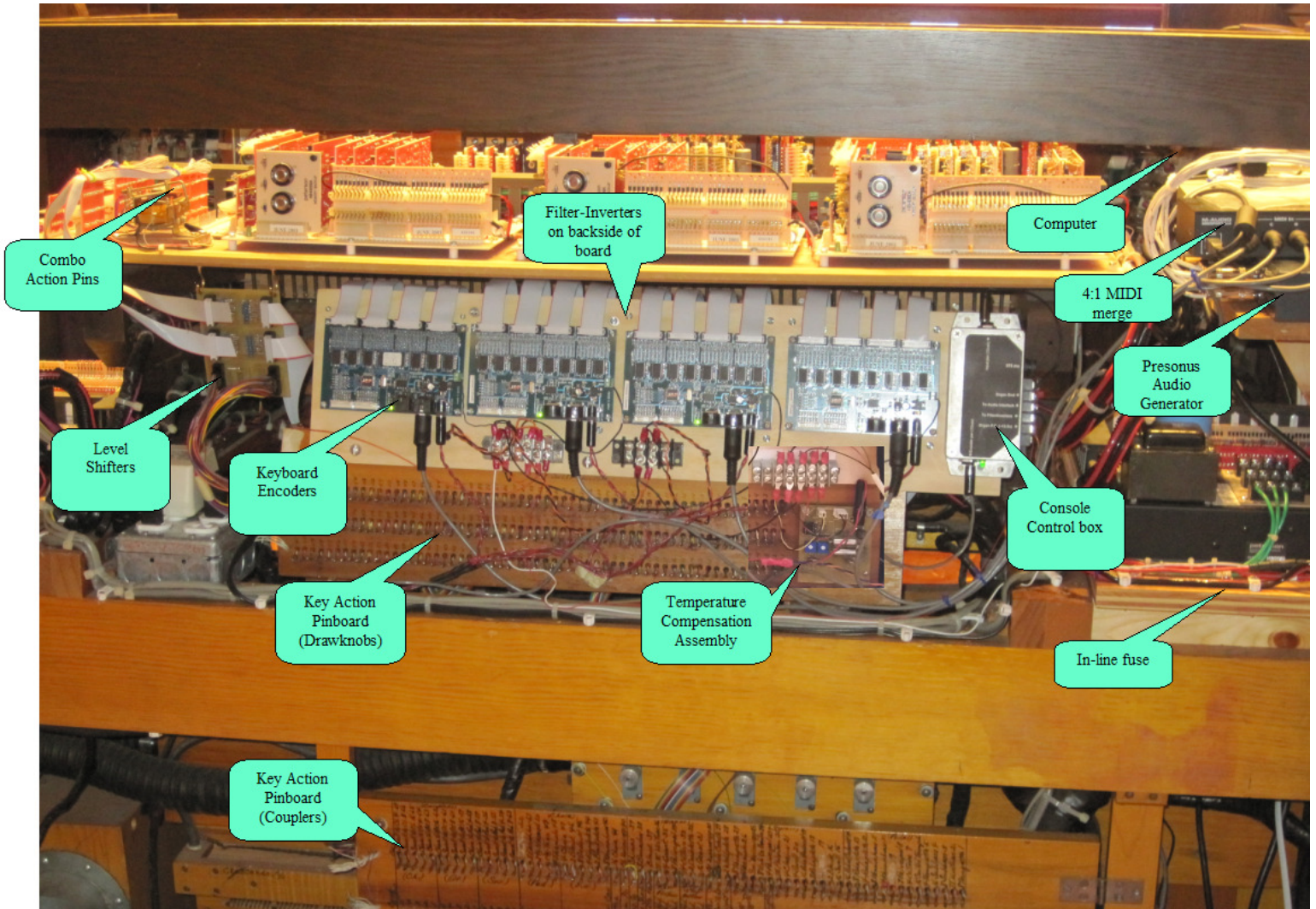

Figure 1.5. Component placement on the rear of the organ console.

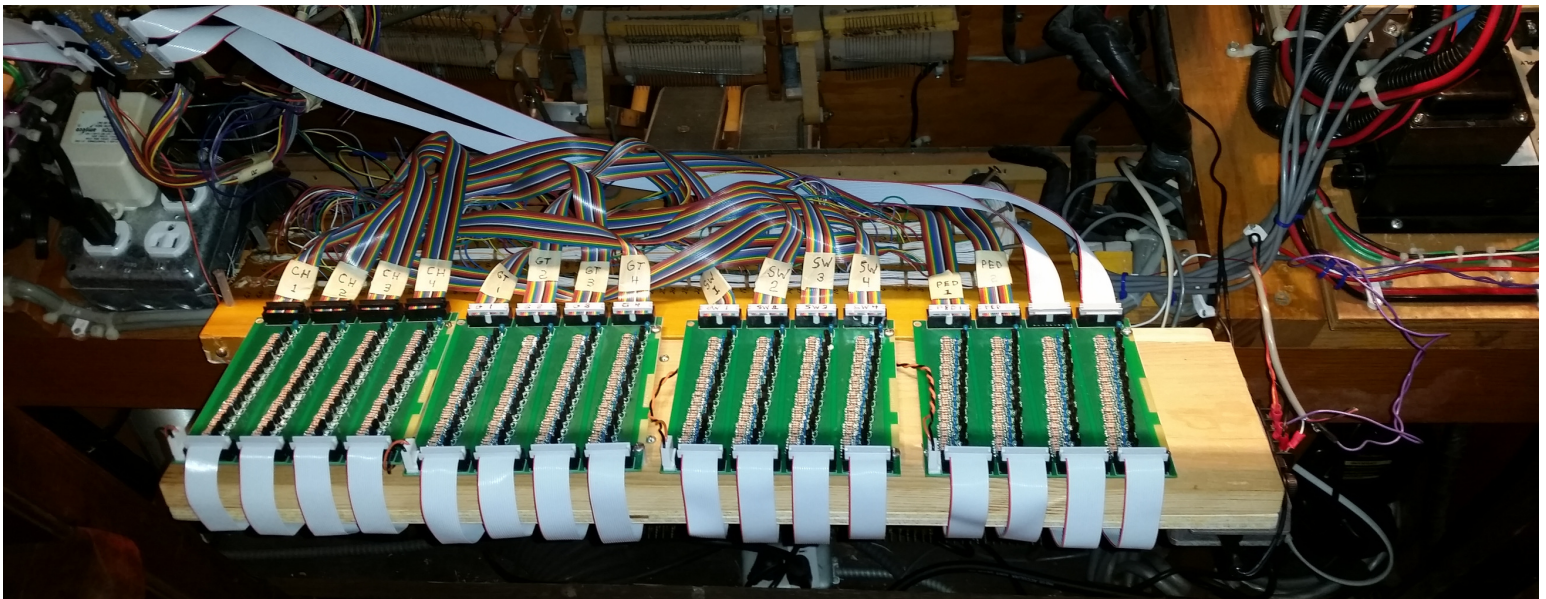

Figure 1.6. Filter Inverters as seen with mounting board folded down.